

bühler

farm king

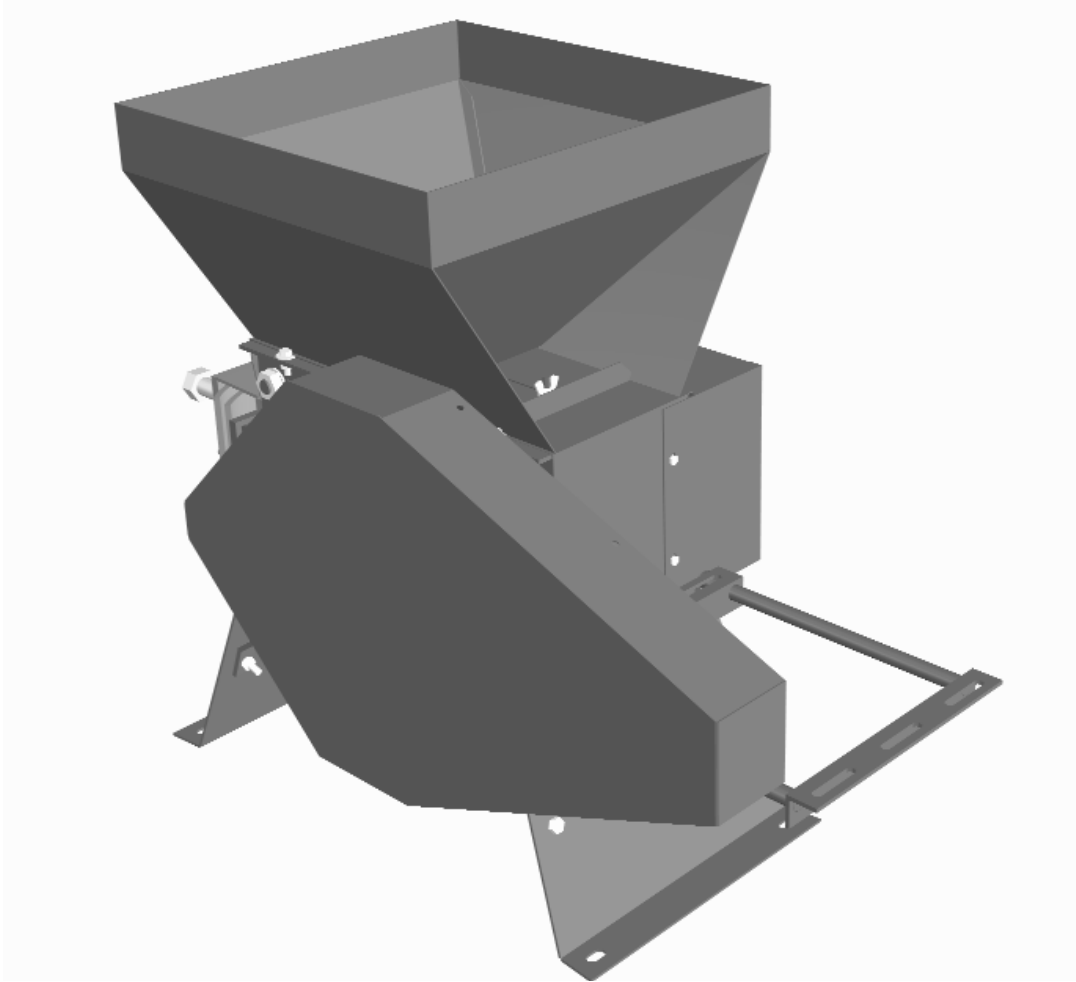

85 & 100 Rollermill

Operator's and Parts Manual
FK317

2006

TABLE OF CONTENTS

DESCRIPTION	PAGE
Warranty	1
Assembly Instructions	2
Operating Instructions.....	3
Safety Instructions	4
Rollermill Drawings	5
Rollermill Parts List	7
PTO Shaft Drawing and Parts List	11
Scraper Assembly.....	12
Rollermill Guard	13
Shipping Bundles	15

WARRANTY POLICY

Buhler Manufacturing products are warranted for a period of twelve (12) months (90 days for commercial application) from original date of purchase, by original purchaser, to be free from defects in material and workmanship under correct, normal agricultural use and proper applications.

Buhler Manufacturing's obligations under this warranty shall be limited to the repair or exchange, at Buhler Manufacturing's option, of any Buhler Manufacturing product or part which proves to be defective as provided. Buhler Manufacturing reserves the right to either inspect the product at the buyer's location or have it returned to the factory for inspection.

The above warranty does not extend to goods damaged or subject to accident, abuse or misuse after shipment from Buhler Manufacturing's factory, nor to goods altered or repaired by anyone other than an authorized Buhler Manufacturing representative.

Buhler Manufacturing makes no Express Warranties other than those, which are specifically described. Any description of goods, including any references and specifications in catalogues, circulars and other written material published, is for the sole purpose of identifying goods and shall conform to such descriptions. Any sample or model is for illustrative purposes only and does not create an Express Warranty that the goods conform to sample or model shown.

The purchaser is solely responsible for determining suitability of goods sold. This warranty is expressly in lieu of all other warranties expressed or implied. Buhler Manufacturing will in no event be liable for any incidental or consequential damages whatsoever. Nor for any sum in excess of the price received for the goods for which liability is claimed.

WARRANTY CLAIMS:

Warranty requests must be prepared on Buhler Manufacturing Warranty Claim Forms with all requested information properly completed. Warranty Claims must be submitted within a thirty (30) day period from date of failure repair.

WARRANTY LABOR:

Any labor subject to warranty **must** be authorized by Buhler Manufacturing. The labor rate for replacing defective parts, where applicable, will be credited at 100% of the dealer's posted shop rate. Defective parts will receive an extra 10% discount to assist with freight or other incidental costs.

GOVERNMENT LEGISLATION:

Warranty terms and conditions are subject to Provincial or State legislation.

IMPORTANT FACTS:

Buckets and Bucket Tines Carry No Warranty
Bent Spears Carry No Warranty
Snowblower Fan Shafts Carry No Warranty
Mower Blades Carry No Warranty
Portable Auger Parts Have Two (2) Year Warranty
Loader Parts Have Two (2) Year Warranty

IMPORTANT NOTE: This warranty does not apply to rentals

ASSEMBLY INSTRUCTIONS

1. Both the #85 and the #100 Rollermills are completely assembled except for the intake hopper (#57). Bolt the hopper to the top of the rollermill using bolts supplied with the hopper.
2. An optional stand with braces (#65 & #66) is available for both models. Bolt the stand underneath the rollermill using 3/8" x 1 1/4" hex bolts, lock washers and hex nuts for the braces and 1/2" x 1 1/4" hex bolts on the stand.
3. A belt drive kit consisting of a 15" single pulley, one B-58 V-belt and a motor mount is supplied with the #85 rollermills. A 3 h.p. electric motor is required for the motor drive. The #85 can also be run with a PTO shaft. The #100 rollermill may be purchased with either a belt drive kit consisting of a 15" double pulley, two B-62 V-belts and a motor mount or a PTO shaft for PTO drive. The 3/8" key is packed in the plastic bag with the manual. A 5 hp electric motor is used for the motor drive. The electric motor pulley must be supplied by the customer. The #85 rollermill requires a 4 1/2", B-groove single pulley. A double 4 1/2" pulley is required for the #100 rollermill electric motors should be 1750 rpm.
4. A magnet for the intake hopper is available as an option for all rollermills. This will keep small metal objects out of the rolled feed and also prevent damage to the roller grooves.
5. **OPTIONAL PTO DRIVE ONLY:** With the engine on the tractor shut off, attach the PTO shaft. The tractor end has a standard 6-spline end with a spring loaded locking pin. The rollermill end has a clamp-style yoke with a 3/8" keyway. Slide the yoke onto the roller shaft with the 3/8" key supplied. The 3/8" key is packed in the plastic bag with the manual. Lock the yoke in place with the 1/2" x 2 3/4" fine thread bolt and lock nut fitted through the groove in the roller shaft. After tightening the bolt, insert and tighten the 3/8" socket set screw supplied.

 **CAUTION:** Always check to see that both ends of the PTO shaft are securely attached every time the rollermill is used. This should always be done with the tractor engine off.

OPERATING INSTRUCTIONS

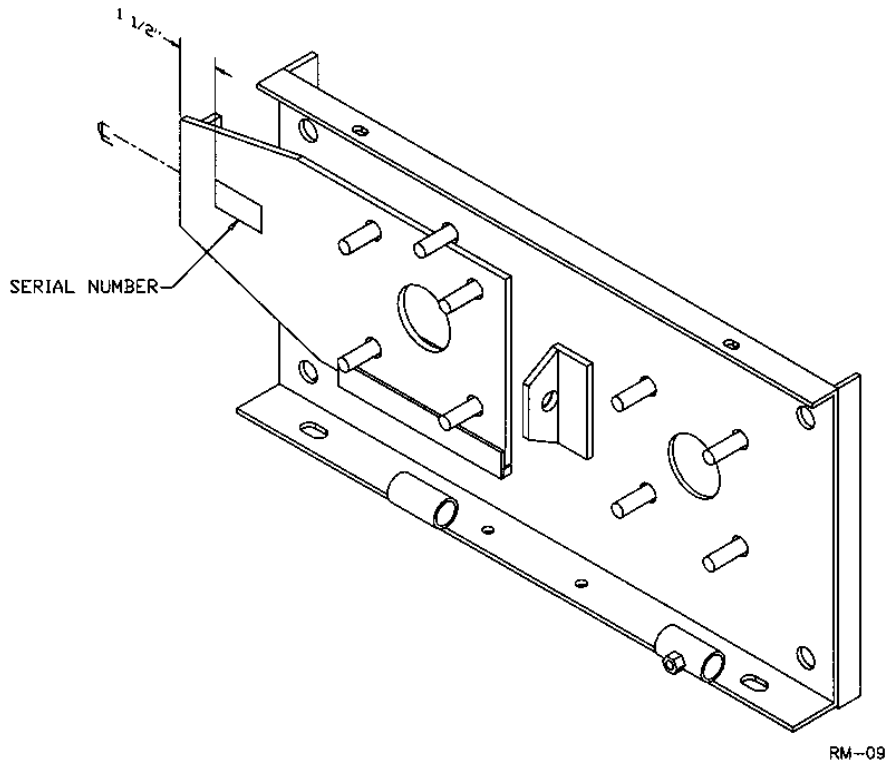

Before using the Rollermill, check the clearance on the rollers. Place a piece of newspaper between the rollers and adjust the set screws on either side of the rollermill till you can feel a slight tension on the paper. The rollers, however, should not touch each other. It is very important that the rollers are evenly adjusted. To ensure good rolling results, check roller adjustment regularly and reset if necessary.

Close the gate control (#20) before starting the rollermill. The intake hopper should be partially full before opening the gate control. Keep the hopper partially filled at all times while the rollermill is running. This will allow the grain to be rolled evenly across the width of the roller and will result in more uniformly rolled feed. It also helps prevent the rollers from wearing unevenly. Before stopping the rollermill, close the gate control while there is still grain in the hopper. When the grain remaining in the machine has all been crushed, shut off the machine immediately. The gate control is left closed until the machine is started again.

To regulate the type of rolled feed one wants, use the adjusting screw (#47). Increased pressure will result in finer and flatter feeds. Decreasing the tension will give you a coarser feed. The roller bearing should be greased approximately every 80 hours or once a season if used less.

⚠️ ALERT: When replacing bearings or tightening a loose bearing collar, always tighten collar in the direction of shaft rotation using a center punch or a similar tool.

SAFETY INSTRUCTIONS

1. Keep hands out of intake hopper when machine is in operation.
2. Keep hands, feet and clothing away from moving parts.
3. Shut off power to adjust, service or clean.
4. Make certain electric motors are grounded.
5. Keep everyone away when machine is in operation. Belts and PTO joints require a particular amount of caution.
6. Keep all guards in place when machine is in operation.

#85 & #100 ROLLERMILL

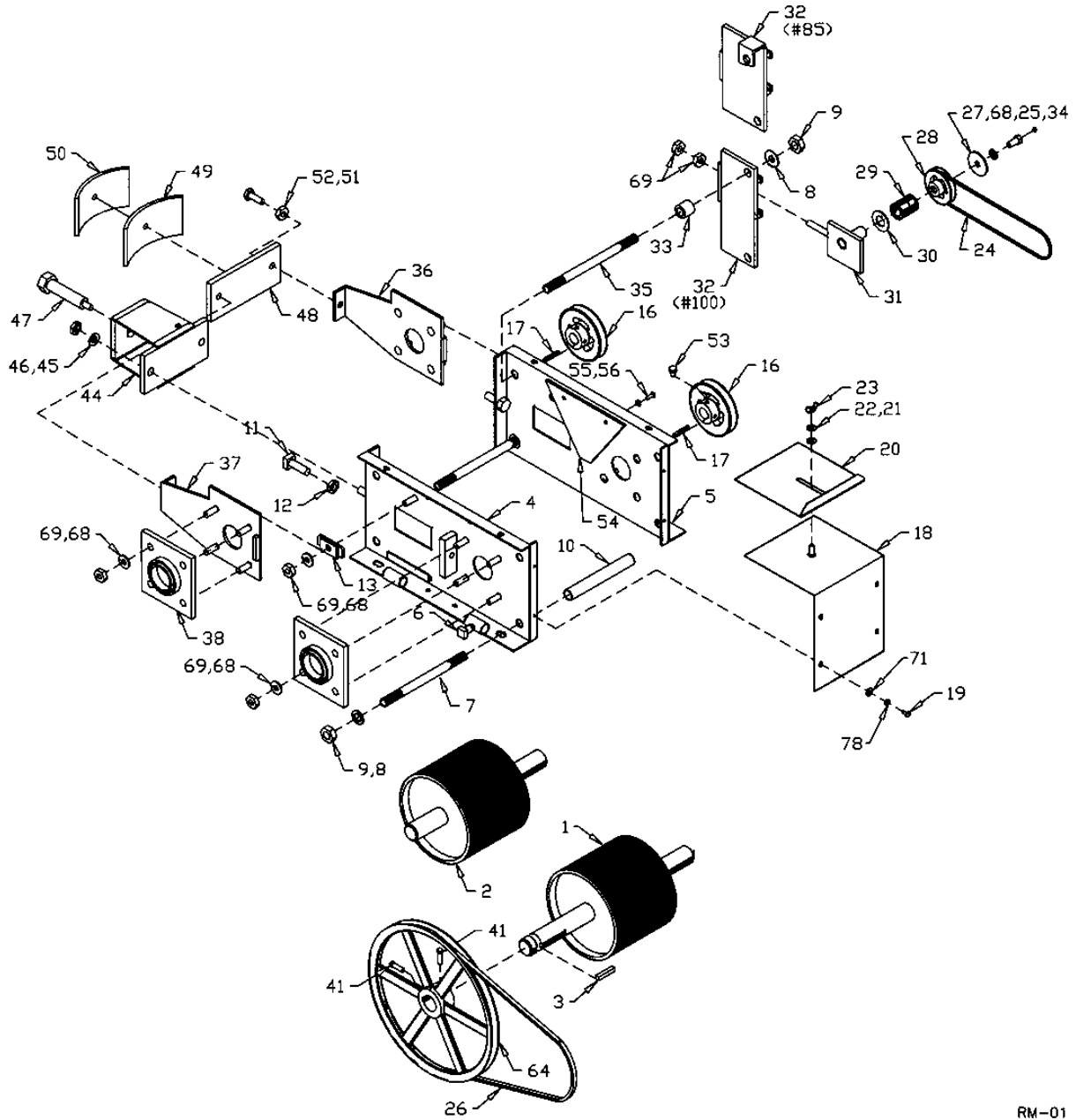

RM-01

WHEN ORDERING PARTS

Always give your dealer the Model, Color and Serial Number of your machine to assist him in ordering and obtaining the correct parts. Use the exploded view and tabular listing of the area of interest to exactly identify the required part.

#85 & #100 ROLLERMILL

Item #	Part #	Description
1	968538	Std. 7" x 8" Rear Roll (8 Groove)
	968539	Chrome 7" x 8" Rear Roll (8 Groove)
	968540	Chrome 7" x 8" Rear Roll (6 Groove)
	968116	Std. 10" x 10" Rear Roll (8 Groove)
	968117	Chrome 10" x 10" Rear Roll (8 Groove)
	901541	Chrome 10" x 10" Rear Roll (6 Groove)
2	968505	Std. 7" x 8" Front Roll (8 Groove)
	968595	Chrome 7" x 8" Front Roll (8 Groove)
	968541	Chrome 7" x 8" Front Roll (6 Groove)
	968105	Std. 10" x 10" Front Roll (8 Groove)
	968195	Chrome 10" x 10" Front Roll (8 Groove)
	901540	Chrome 10" x 10" Front Roll (6 Groove)
	Y8103	Set of Std. Rolls For #85 Rollermill (8 Groove)
	Y8104	Set of Std. Rolls For #100 Rollermill (8 Groove)
	Y8108	Set of Chrome Rolls For #85 Rollermill (8 Groove)
	Y8109	Set of Chrome Rolls For #100 Rollermill (8 Groove)
Y8117	Set of Chrome Rolls For #85 Rollermill (6 Groove)	
Y8118	Set of Chrome Rolls For #100 Rollermill (6 Groove)	
3	968807	3/8" x 3/8" x 2" Key
4	968504	Left Side (Model #85)
	968104	Left Side (Model #100)
5	968513	Right Side (Model #85)
	968113	Right Side (Model #100)
6	9810943	5/16" x 3/4" Sq. Hd. Set Screw
7	968509	Frame Bolt (3 Used) (#85) 3/4" x 10"
	968109	Frame Bolt (2 Used) (#100) 3/4" x 13"
8	81701	3/4" Lock Washer (pl)
9	81700	3/4" Hex Nut (pl)
10	968508	Frame Spacer (4 Used) (#85) 1.05" x 7 5/8"
	968108	Frame Spacer (4 Used) (#100) 1.05" x 10 5/8"
11	968802	5/8" x 2" Sq. Hd. Set Screw
12	84126	5/8" Jam Nut (pl)
13	968803	Slide Bracket (2 Used)
14	968599	Pto Guard

15	968600	Guard Insert (#85)
	968199	Guard Insert (#100)
16	968816	6" Pulley, B-Groove, 1 1/2" Bore
17	901550	1/4" x 1/4" x 1 3/4" Key
18	968510	Rear Cover Plate (#85)
	968110	Rear Cover Plate (#100)
19	81523	1/4" x 1/2" Hex Bolt (pl)
20	968515	Gate Control (#85)
	968115	Gate Control (#100)
21	84000	3/8" Flat Washer (pl)
22	81593	3/8" Lock Washer (pl)
23	84217	3/8" Wing Nut (pl)
24	968518	Drive Belt (#85) - BB46
	968818	Drive Belt (#100) - BB51
25	110339	1/2" Grease Zerk Bolt
26	968586	Drive Belt For #85 Rollermill (B-58)
	973621	Drive Belt For #100 Rollermill (B-62)
27	901504	2 1/4" OD. Flat Washer
28	968822	4" Idler Pulley, B-Groove, 1 1/2" Bore
29	968827	Roller Bearing
30	84522	1" SAE Flat Washer (pl)
31	901500	Tightener Weldt
32	901494	Bracket Weldt (#85)
	901503	Bracket Weldt (#100)
33	901495	Spacer 1 1/4" OD. x 1 1/8" Long
34	967900	1/4" Grease Fltg
35	968530	Frame Bolt (1 Used) (#85) 3/8" x 11"
	968130	Frame Bolt (2 Used) (#100) 3/4" x 14"
36	968537	Adjustable Bearing Holder (#85) R
	968837	Adjustable Bearing Holder (#100) R
37	968501	Adjustable Bearing Holder (#85) L
	968801	Adjustable Bearing Holder (#100) L
38	968632	1 1/2" Bearing Flange & Insert
	968627	1 1/2" Bearing Only
39	86170	3/8" x 1" Hex Bolt (pl)
40	909277	Manual Holder
41	812037	3/8" x 3/4" Sq. Hd Set Screw (pl)
42	968531	Front Cover (#85)
	968131	Front Cover (#100)
43	81549	5/16" x 3/4" Hex Bolt (pl)
44	968536	Spring Support (#85)
	968136	Spring Support (#100)
45	81677	5/8" Lock Washer (pl)
46	81676	5/8" Hex Nut (pl)

47	968832	Adjusting Screw
48	968535	Spring Plate (#85)
	968135	Spring Plate (#100)
49	968534	5/16" x 4" x 7" Spring (#85)
	968134	5/16" x 4" x 10" Spring (#100)
50	968533	5/16" x 4" x 6" Spring (#85)
	968133	5/16" x 4" x 9" Spring (#100)
51	812364	1/2" Lock Nut NC (pl)
52	967166	1/2" x 1 1/2" Flat Hd Socket Bolt
53	985639	3/8" x 1/2" Socket Set Screw
54	968512	Belting Seal (#85)
	968812	Belting Seal (#100)
55	9812399	1/4" x 3/4" Flat Hd Stove Bolts
56		1/4" Sq Nuts (Incl. With Bolts)
57	968583	Hopper For #85 Rollermill
	968183	Hopper For #100 Rollermill
58	F7410	Magnet For #85 Rollermill
	F7510	Magnet For #100 Rollermill
59	812026	5/16" x 1" Hex Bolt (pl)
60	81570	5/16" B.S. Flat Washer (pl)
61	81569	5/16" Lock Washer (pl)
62	81568	5/16" Hex Nut (pl)
63	968587	Motor Mount For #85 Rollermill
	968187	Motor Mount For #100 Rollermill
64	968585	15" Single Pulley (#85)
	968185	15" Double Pulley (#100)
65	968591	Stand Only (#85) - 2 Req'd
	968191	Stand Only (#100) - 2 Req'd
66	968592	Brace Only (#85) - 4 Req'd
	968192	Brace Only (#100) - 4 Req'd
	F7420	Stand For #85 Rollermill (Set)
	F7520	Stand For #100 Rollermill (Set)
67	81620	1/2" x 1 1/4" Hex Bolt (pl)
68	81637	1/2" Lock Washer (pl)
69	81636	1/2" Hex Nut (pl)
70	86171	3/8" x 1 1/4" Hex Bolt (pl)
71	81546	1/4" Flat Washer (pl)
72	81592	3/8" Hex Nut (pl)
73	968590	Roll Scraper Left Angle (#85)
	968190	Roll Scraper Left Angle (#100)
74	901705	Roll Scraper Right Angle (#85)
	901708	Roll Scraper Right Angle (#100)
75	968589	Roll Scraper - 7 1/8" (#85)
	968189	Roll Scraper - 10 1/8" (#100)

76	968597	18" x 23" Guard (#85)
	968197	21" x 27" Guard (#100)
77	81525	1/4" x 3/4" Hex Bolt (pl)
78	81545	1/4" Lock Washer (pl)
79	81544	1/4" Hex Nut (pl)
80	968598	#85 - Electric Motor Drive Guard
	968198	#100 - Electric Motor Drive Guard
81	909675	PTO Shaft
82	81627	1/2" x 3" Hex Bolt NF (pl)
83	812364	1/2" Lock Nut NF (pl)
84	988999	3/8" x 3/8" Socket Set Screw (pl)

Rollermill PTO Shaft

Item #	Part #	Description
	909675	Shaft Complete
1	936266	Clamp Yoke
2	936051	Yoke & Tube Assembly
3	936052	Yoke & Shaft Assembly
4	936214	Inner Shield
5	936215	Outer Shield
6	936111	Shield Bearing Kit
7	936025	Repair Kit
8		Spring Pin
9	909674	6 Spline End Yoke
	936026	21 Spline End Yoke
10	967179	1/2" x 3" Fine Thread Bolt
11	967105	1/2" Fine Thread Lock Nut

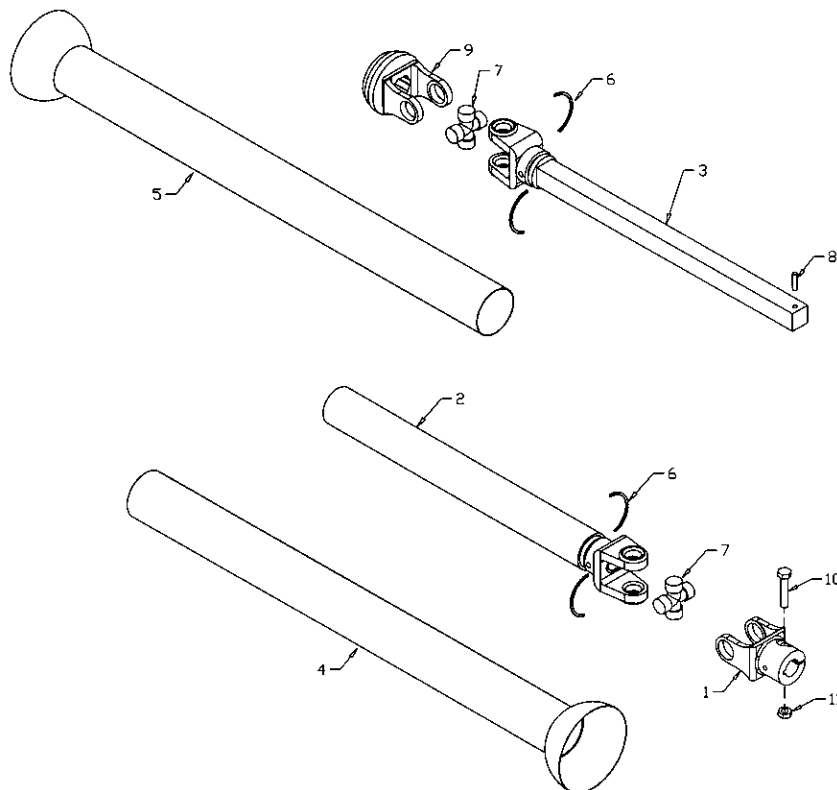

RM-08

#85 & #100 ROLLERMILL ROLL SCRAPER ASSEMBLY
(OPTIONAL)

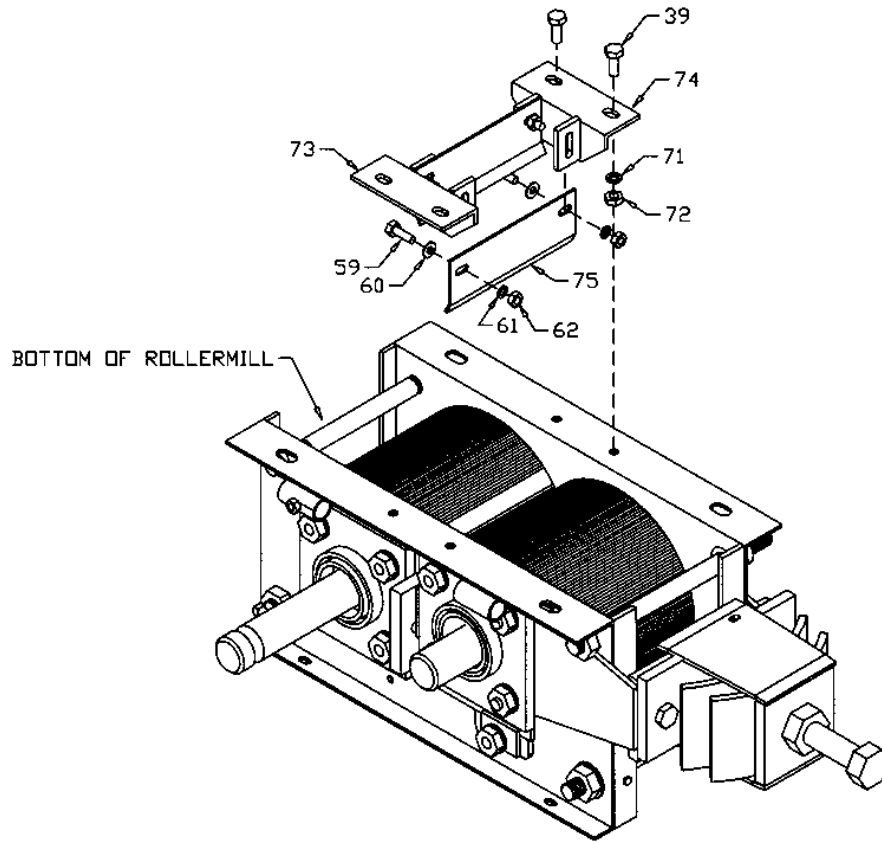

RM-03

- Turn rollermill upside down as shown.
- Bolt the left and right angle irons to the rollermill sides in the holes near the center using 3/8" x 1" hex bolts, lock washers and hex nuts.
- Fasten the scrapers to the inside of the flat iron brackets welded to the angle irons using 5/16" x 1" hex bolts, flat washers, lock washers and hex nuts. The lip on the scrapers is turned to the center of the rollermill.
- Adjust the scraper height so the scrapers are just short of touching the rolls.

#85 & #100 ROLLERMILL GUARD

Drive Pulley Guard:
- used on Rollermills

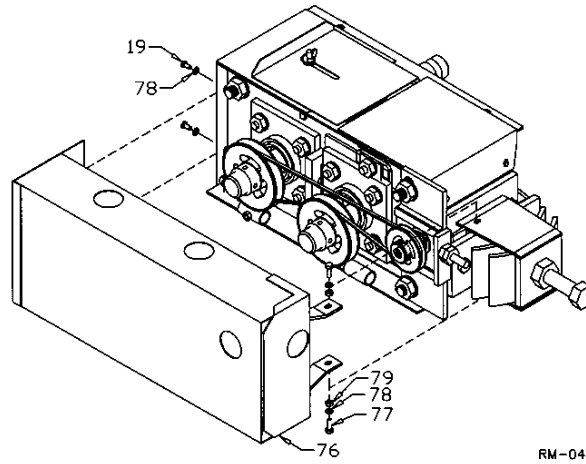

Belt Drive Guard:
- used on Rollermills with
Electric Motor Drive

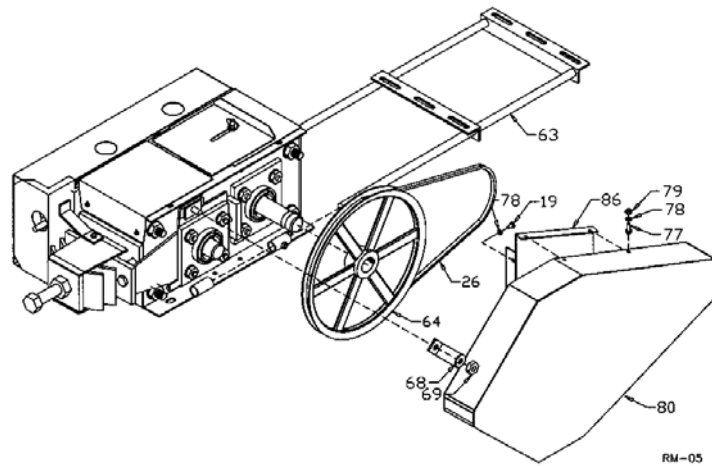

PTO Drive Guard:
- used on Rollermills with PTO Drive

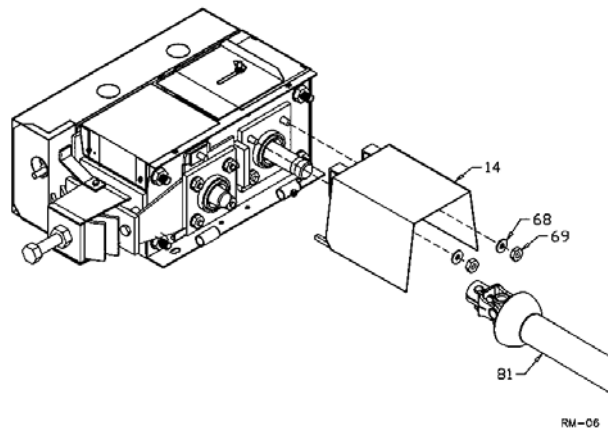

#85 & #100 ROLLERMILL GUARDS**DRIVE PULLEY GUARD:**

All rollermills are supplied with a drive pulley guard (#76). One end of the guard is bolted to the two holes punched in the spring holder using $\frac{1}{4}$ " x $\frac{3}{4}$ " hex bolts, lock washers and hex nuts. The other end is bolted on using the same bolts that hold on the rear cover plate.

BELT DRIVE GUARD:

Rollermills with an electric motor drive use an additional belt drive guard (#80). Bolt the guard insert (#15) to the rollermill using the same bolts that hold on the rear cover plate. Assemble the motor mount, electric motor, belts and pulleys. Bolt the guard to the insert using the $\frac{1}{4}$ " x $\frac{3}{4}$ " hex bolts, lock washers and hex nuts supplied. Bolt on the end of the guard using the same bolt that holds on the slide bracket.

PTO DRIVE GUARD:

Rollermills with a PRO drive use a PTO guard (#14). This guard bolts on using the top two bolts on the bearing flange.

 **CAUTION:** Never use the rollermill without all the appropriate guards in place. Always turn off the machine before removing any guard or when servicing.

#85 ROLLERMILL – BUNDLE NUMBERS

QUANTITY REQUIRED	BUNDLE NUMBER	DESCRIPTION
Y85 #85 ROLLERMILL		
1	F7400	Std. Rollermill
1	F7404	Belt Drive Kit
1	F7405	Hopper
Y85C #85 ROLLERMILL w/chromed Rolls		
1	F7403	Rollermill – chromed rolls
1	F7404	Belt Drive Kit
1	F7405	Hopper
Y85C-6 #85 ROLLERMILL w/chromed corn rolls		
1	F7404	Belt Drive Kit
1	F7405	Hopper
1	F7408	Rollermill – w/chromed 6 groove rolls
OPTIONS		
F7410	Holder Magnet	
F7420	Stand	
F7402	Scraper	
Y8501	PTO Kit	

#100 ROLLERMILL – BUNDLE NUMBERS

Y100 #100 ROLLERMILL		
1	F7500	Std. Rollermill
1	F7501	Hopper
Y100C #100 ROLLERMILL w/chromed Rolls		
1	F7501	Hopper
1	F7403	Rollermill – chromed rolls
Y100C-6 #100 ROLLERMILL w/chromed corn rolls		
1	F7501	Hopper
1	F7508	Rollermill – w/chromed 6 groove rolls
OPTIONS		
Y8501	PTO Kit	
F7550	Belt Drive Kit	
F7510	Holder Magnet	
F7520	Stand	
F7502	Scraper	

DIVISION LOCATIONS

Farm King Division
301 Mountain Street S.
Morden, MB R6M 1X7
Ph.: (204) 822-4467
Fax: (204) 822-6348

Allied Division
1201 Regent Ave. W.
Box 1003
Winnipeg, MB R2C 3B2
Ph.: (204) 661-8711
Fax: (204) 654-2503

Inland Division
675 Washington Ave.
Winnipeg, MB R2K 1M4
Ph: (204) 667-7854
Fax: (204) 669-2599

B.I.I. Division
1330 43rd Street N.W.
Fargo, ND 58102
Ph: (701) 282-7014
Fax: (701) 282-5865

CANADIAN WAREHOUSES

B.C., Abbotsford
(604) 864-2665

AB, Edmonton
(403) 962-6991

SK, Regina
(306) 781-2300

ON, Woodstock
(519) 539-0435

ON, Jasper
(613) 283-1758

QC, Dorion
(450) 455-4840

U.S. WAREHOUSES

AR, West Memphis
(870) 732-3132

GA, Stone Mountain
(770) 908-9439

IA, Lakeview
(712) 657-8585

ID, Meridian
(208) 887-6006

IN, Clarksville
(812) 284-3376

KS, Wichita
(316) 265-9577

MN, Lakeville
(952) 469-5267

MT, Billings
(406) 248-7771

ND, Bismarck
(701) 223-1886

ND, Fargo
(701) 282-7003

NY, Syracuse
(315) 463-5276

OH, Youngstown
(330) 793-0862

OR, Portland
(503) 234-0378

SD, Huron
(605) 352-8616

TX, Houston
(713) 928-2632

UT, Salt Lake City
(801) 972-4321

WI, Portage
(608) 742-1370

OFFSHORE WAREHOUSES

Burando Hill
Katanning
W. Australia
011-618-98-214422

Chihuahua, Mexico
011-52-158-90306

John Kerr Equipment Ltd.
Wilcoxholm Farm
Linlithgow, W. Lothian
Scotland
011-441-506-842280

Skovde, Sweden
011-46-500-452651

Naestved, Denmark
011-45-557-29511

bühler

Buhler Manufacturing "a partnership"

301 Mountain Street S.
Morden MB.
R6M 1X7
Ph.: (204) 822-4467
Fax: (204) 822-6348
www.buhler.com